

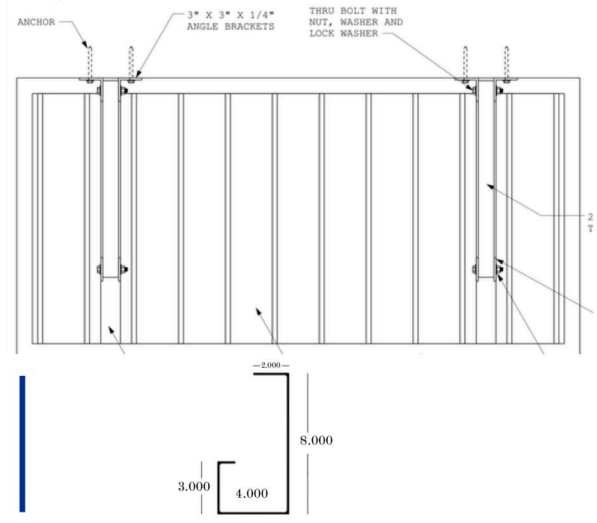

Aluminum Canopy

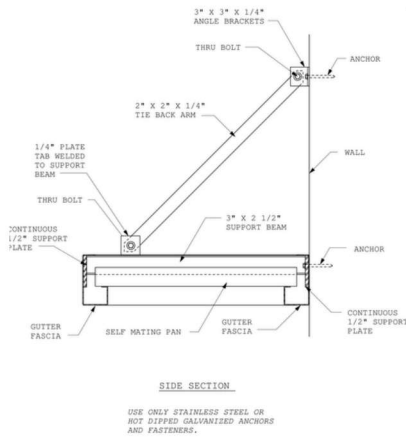

J-Fascia (Gutter) (6063 T6 - MILL FINISH)

Part Number	Size	Length (In)	Approx. wt/lin ft
120-170-63	8" x 4" x 3" J-Fascia (Gutter)	288	2.713

Self Mating Pan (6063 T6 - MILL FINISH)

Part Number	Size	Length (In)	Approx. wt/lin ft
110-170-63	3" x 6" Self Mating Pan (Canopy)	288	1.026

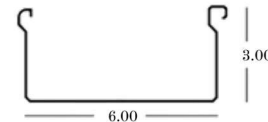

Canopy Support Beam

Part Number	Alloy & Temper	Size	Length (In)	Approx. wt/lin ft
115-70-61	6061 T6	3" x 2.5" x .130" AA I-Beam	300	2.068
160-40-63	6063 T52	2" Sq. x .250" w. Square Tube	288	2.1

Tie Back Arm

Part Number	Alloy & Temper	Size	Length (In)	Approx. wt/lin ft
155-40-63	6063 T52	2" Sq. x .125 w. Square Tube	288	1.126
115-55-61	6061 T6	1 1/4 Sch. 40 Pipe	240	.786
120-55-61	6061 T6	1 1/2 Sch. 40 Pipe	240	0.94

Available for Mill Order